

INSPIRED BY EFFICIENCY



CATALOG



PALLET CONVEYOR MODULES

STACKER CRANE

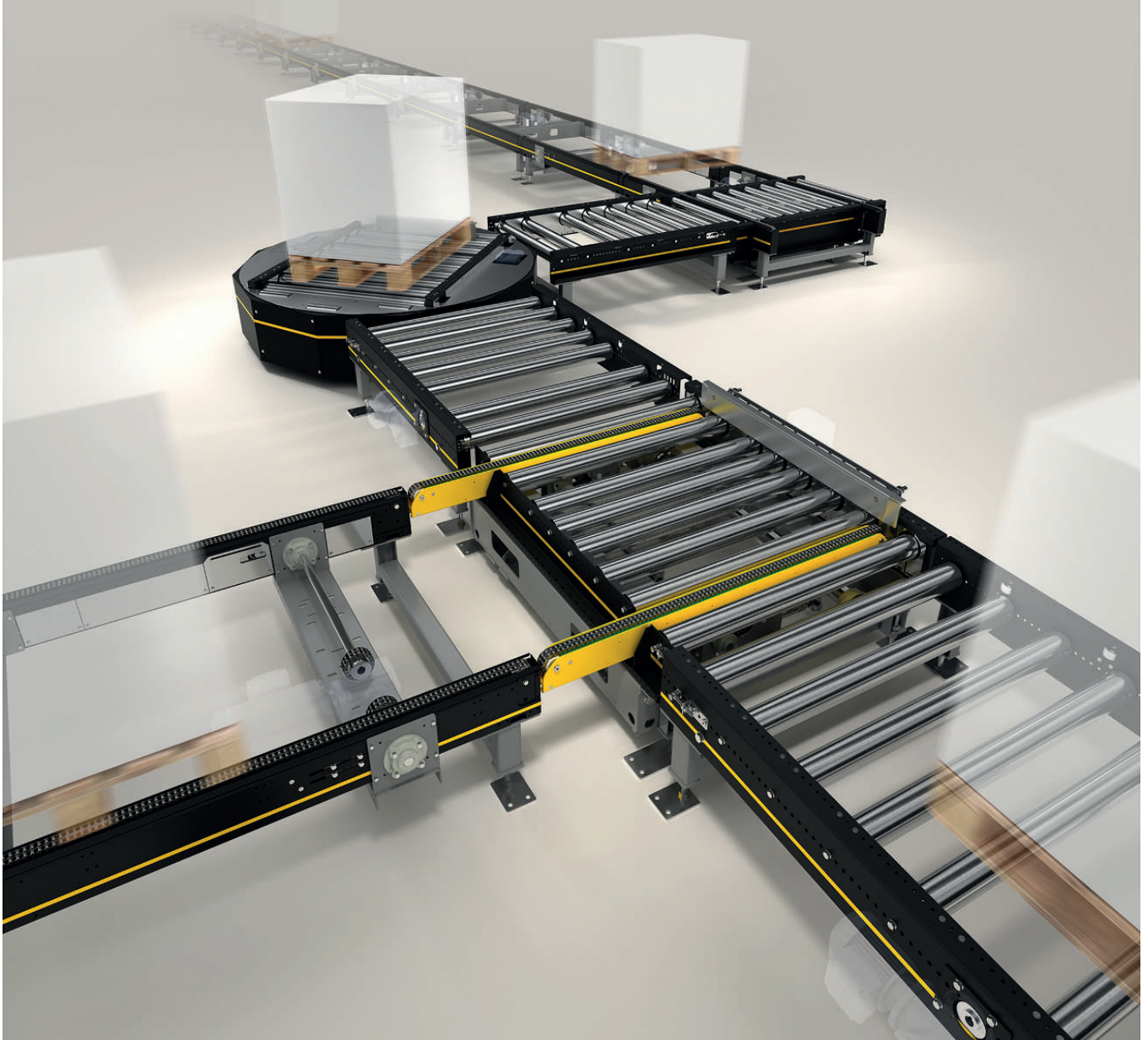
TRANSFER CAR

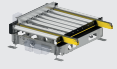
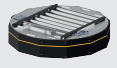

PRODUCT LOCATOR

Products	Pallet type										Drive		Torque transmission			Page	
	EUR EPAL pallet		Plastic EPAL pallet		Industrial pallet		Closed block pallet		GMA pallet		Pallet Drive	Gear motor	RollerDrive	Roller-to-roller	Tangential		
	Long-way	Cross-way	Long-way	Cross-way	Long-way	Cross-way	Long-way	Cross-way	Long-way	Cross-way							
Roller Conveyor 	PM 9710	●	-	●	-	●	-	●	●	-	●	-	●	-	-	●	10
	PM 9711	●	-	●	-	●	-	●	●	-	●	●	-	-	●	-	14
	PM 9712	●	-	●	-	●	-	●	-	●	-	-	-	●	●	-	18
	PM 9715	●	●	●	●	●	●	●	●	●	●	-	●	-	-	●	22
Chain Conveyor 	PM 9720	●	●	●	●	●	●	●	●	●	●	-	●	-	-	-	26
Transfer 	PM 9730	Roller	Chain	Roller	Chain	Roller	Chain	Roller/chain	Roller/chain	Chain	Roller	-	●	-	-	●	30
	PM 9732	Roller	Chain	Roller	Chain	Roller	Chain	Roller/chain	Roller/chain	Chain	Roller	-	●	-	-	●	34
Turntable 	PM 9735	●	-	●	-	●	-	●	-	-	●	-	●	-	-	●	38
	PM 9737	-	●	-	●	-	●	●	-	●	-	-	●	-	-	●	42
Stacker Crane PM 9770	●	-	●	-	-	-	-	-	-	-	-	-	-	-	-	-	46
Transfer Car PM 9750	●	-	●	-	-	-	-	-	-	-	-	-	-	-	-	-	48

● = suitable - = not suitable

Symbols



Max. load capacity 1200 kg per pallet



Suitable for EUR EPAL pallet



Suitable for closed block pallet



Suitable for GMA pallet



Suitable for industrial pallet



Suitable for plastic EPAL pallet



Gear motor



Pallet Drive/RollerDrive (for PM 9712)



Roller-to-roller chain drive



Tangential chain drive

Contents

The Interroll Group	4
Interroll Platform for Pallet Conveyor Modules	6
Product Overview	8
Roller Conveyor	10
Chain Conveyor	26
Chain Transfer	30
Roller Transfer	34
Turntable	38
Interroll Stacker Crane	46
Transfer Car	48
Controls	50
Application Notes	55



www.interroll.com

THE INTERROLL GROUP

The Interroll Group is a globally leading supplier of high-quality key products and services for internal logistics.

The company, which is listed on the stock exchange and has its headquarters in Switzerland, employs some 2400 people (in 2019) in 34 companies (in 2019) around the globe.

The solutions for our customers' daily logistical challenges are based on Interroll key products that are built on a worldwide common platform.



Conveyor Rollers

Interroll is the worldwide leading provider of conveyor rollers that can be found in a multitude of applications in internal logistics. For the roller production, we merge quality, flexibility and speed. More than 13 million rollers in 60,000 variants leave our plants worldwide every year. Our production is always order-driven, even for the smallest order quantities and, if desired, even with a delivery time of 24 hours. Proven.



Drives and Controls

Interroll is a leading manufacturer in the segment of DC motor rollers and drum motors.

Interroll RollerDrive and their controls are used in automated conveyor technology. Energy-efficient DC drives are installed in decentralized conveyor systems and, as a result, optimize energy demand and material handling. The bus interface enables integrating the zero pressure accumulation conveyor technology into Industry 4.0 systems.

Interroll Drum Motors are designed for use in belt conveyors and conveyor systems. These robust, high-quality belt drives enable the construction of maintenance-free, energy-efficient conveyor belt systems for the majority of industrial applications as well as for food processing, baggage handling and supermarket checkouts.



Holding



Sales, Production & Service



Global Competence Centers



Regional Competence Centers

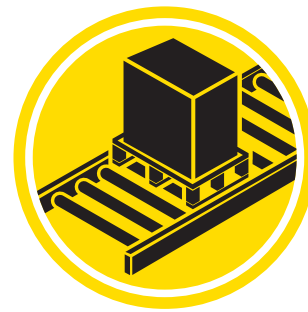

Conveyors & Sorters

The Modular Conveyor Platform (MCP) from Interroll offers highest flexibility: a broad spectrum of modules, consisting of roller conveyors, belt conveyors as well as key products such as transfer, high-performance diverts or spiral lifts, covers all requirements of the material handling.

The Interroll crossbelt sorters were developed with an eye on precision for fast and precise sorting of goods of all types from 50 g to 35 kg. More than 400 Interroll sorters are used every day by the largest CEP players and E-commerce enterprises worldwide.

The brand-new modular pallet conveyor platform (MPP) offers roller and chain conveyors as well as special conveyors such as transfers and turntables to create a fully integrated, robust, space-saving and energy-saving solution for high throughput handling of pallets.

Pallet & Carton Flow

Interroll Pallet Flow and Carton Flow are the first choice when it comes to rapid turnarounds and optimizing the storage and commissioning process. Thanks to its efficiency and robustness, Pallet Flow ensures long-term availability and more flexibility for peaks in orders. The compact design reduces space requirements by up to 50 percent compared to conventional solutions. The integrated TimePlus Separator as well as the Magnetic Speed Controller increase the safety of the work environment and significantly reduce the risk of damages to goods.

The Interroll Carton Flow solutions are efficient as well as ergonomic, and were developed to improve the commissioning output.

INTERROLL PLATFORM FOR PALLET CONVEYOR MODULES

Introduction of the new modular conveyor platform for pallets

Reliable and efficient handling of pallets plays an important role in the material flow. High-capacity storage that uses the least amount of space is not the only aim here. It is just as important to minimize the transportation times between goods receipt and goods issue or storage, or between production and picking areas in companies, and automate them for high efficiency – while at the same time benefiting from streamlined planning processes, a

low installation workload and flexible design options. The new modular pallet conveyor platform MPP is a versatile solution for handling pallets. Combined with the company's tried-and-tested flow storage solution, Interroll's new pallet conveyor platform provides the ideal basis for creating comprehensive storage and conveyor solutions for all kinds of applications.

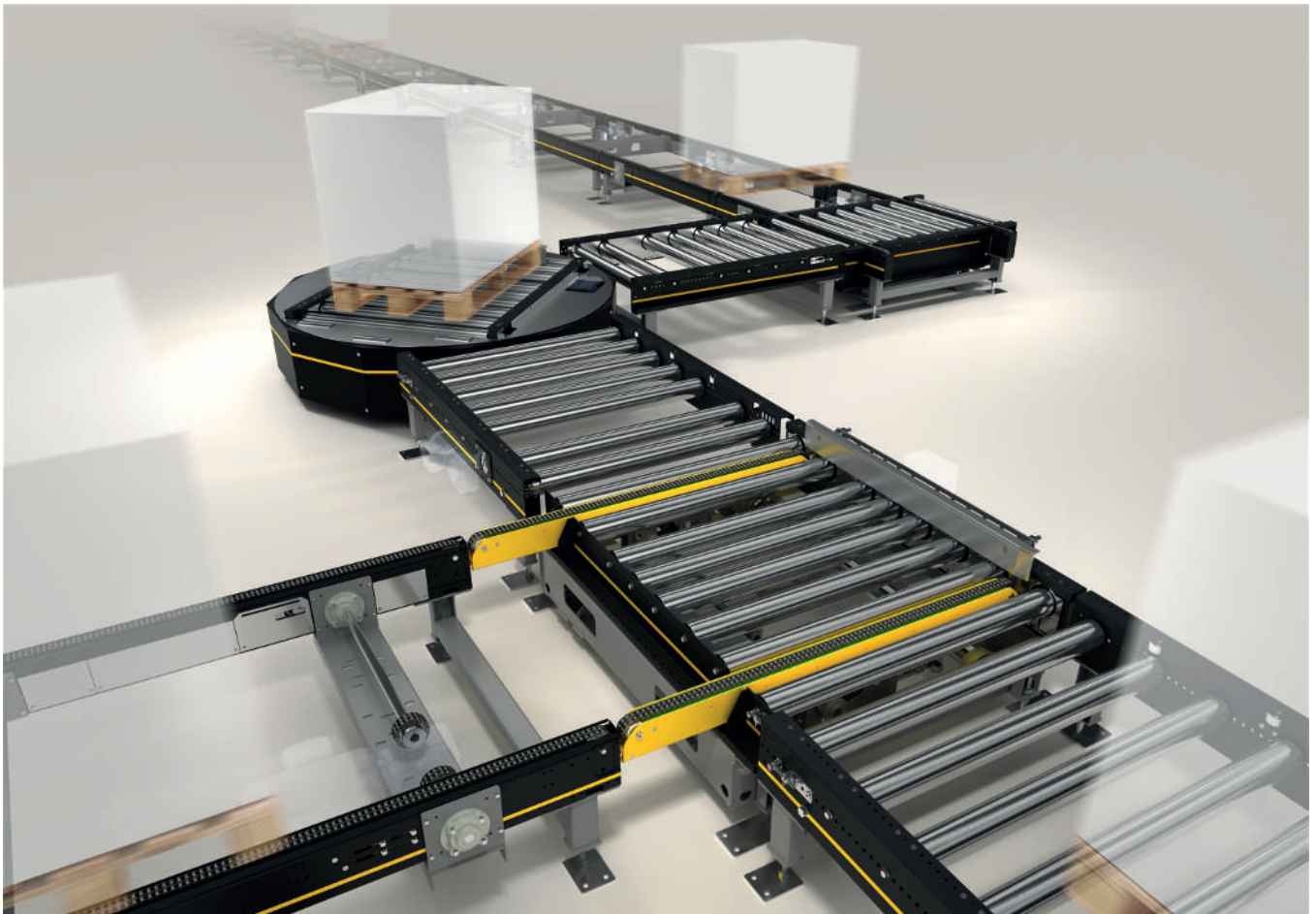

INTERROLL PLATFORM FOR PALLET CONVEYOR MODULES

Flexibility and robustness make the difference



Customized applications

The modules can transport pallets with a weight of up to 1200 kilogram at a maximum speed of 0.5 meters per second. The temperature range is from -28 to +40 degrees Celsius, which means that the MPP can even be used in the deep freeze area. Depending on the control system used, it is possible to design the system for different weights, run it at variable speeds or integrate positioning functions.



Space-saving design

A conveyor solution, combining various modules, is installed at a height of 350 millimeters, making it very easy to insert and remove the pallets using a forklift truck. Lower assembly heights are also possible for a simple conveyor line.



Minimal installation effort

The modules are perfectly matched and each delivered fully pre-assembled, minimizing installation time. An additional advantage of the modular structure is that later changes and enhancements to the material flow or system are easy and cost-efficient.



Simple planning, flexible design

Designing and creating the fully modular system is straightforward and user-friendly with the popular Interroll Layouter tool. The MPP encompasses chain or roller conveyors as well as additional modules such as 90-degree turning units and rotary plates. Special modules for specific functions are also available on request.

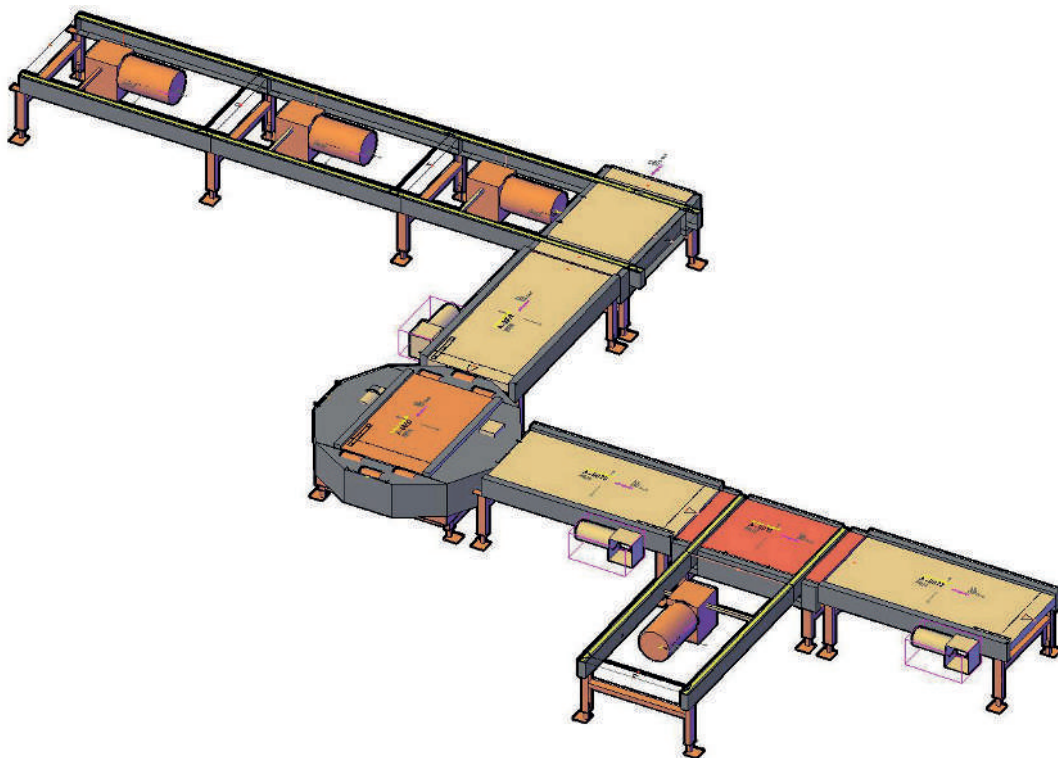

PRODUCT OVERVIEW

Straight Conveyors



Roller Conveyor
PM 9710 | page 10

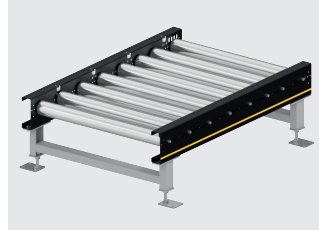

Roller Conveyor
PM 9711 | page 14

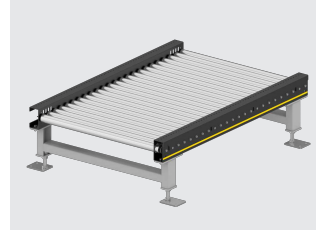

Roller Conveyor
PM 9712 | page 18

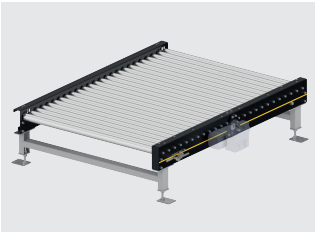

GMA Roller Conveyor
PM 9715 | page 22

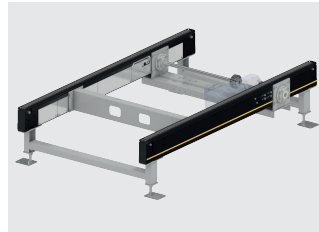

Chain Conveyor
PM 9720 | page 26

Transfers

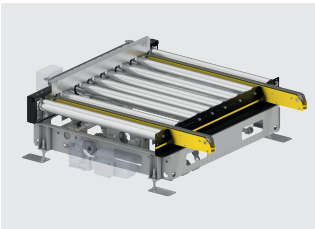

Chain Transfer
PM 9730 | page 30

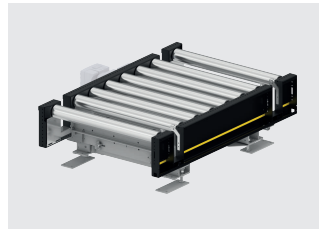

Roller Transfer
PM 9732 | page 34

Turntables

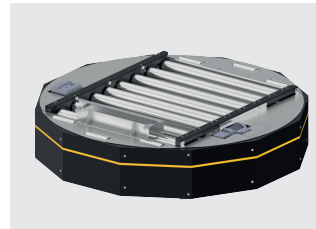

Turntable with Roller Conveyor
PM 9735 | page 38

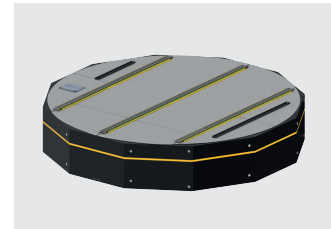

Turntable with Chain Conveyor
PM 9737 | page 42

Stacker Crane



Stacker Crane
PM 9770 | page 46

Transfer Car

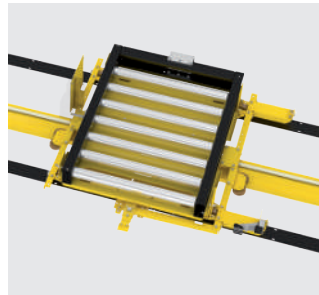

Transfer Car
PM 9750 | page 48

Accessories

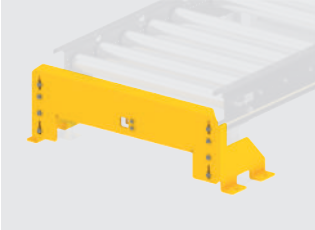

Impact Protection

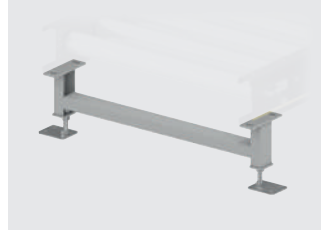

Support

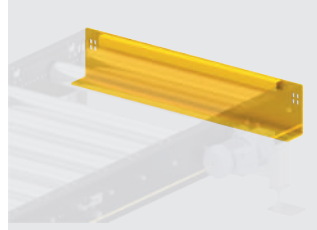

End Stop



Feeding Chute



Running Boards



Photo Cell Holder



Driven Torque Transmissions



Chain Conveyor Side Guide

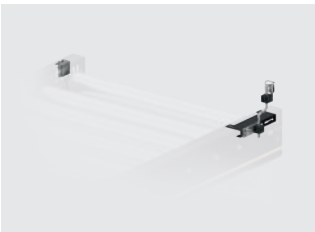

Sensor Support

ROLLER CONVEYOR PM 9710



Product description

The roller conveyor is suited for horizontal transport of full and empty pallets. The rollers can be relocated quickly due to the tangential drive principle and frame design. The chain tensioning station on the outside allows for easy re-tensioning of the precision roller chain.

At the same time, the rigid frame profile serves as side guide. The drive can be installed on the right side or optionally on the left in the direction of travel. Floor irregularities can easily be compensated with adjustable supports.

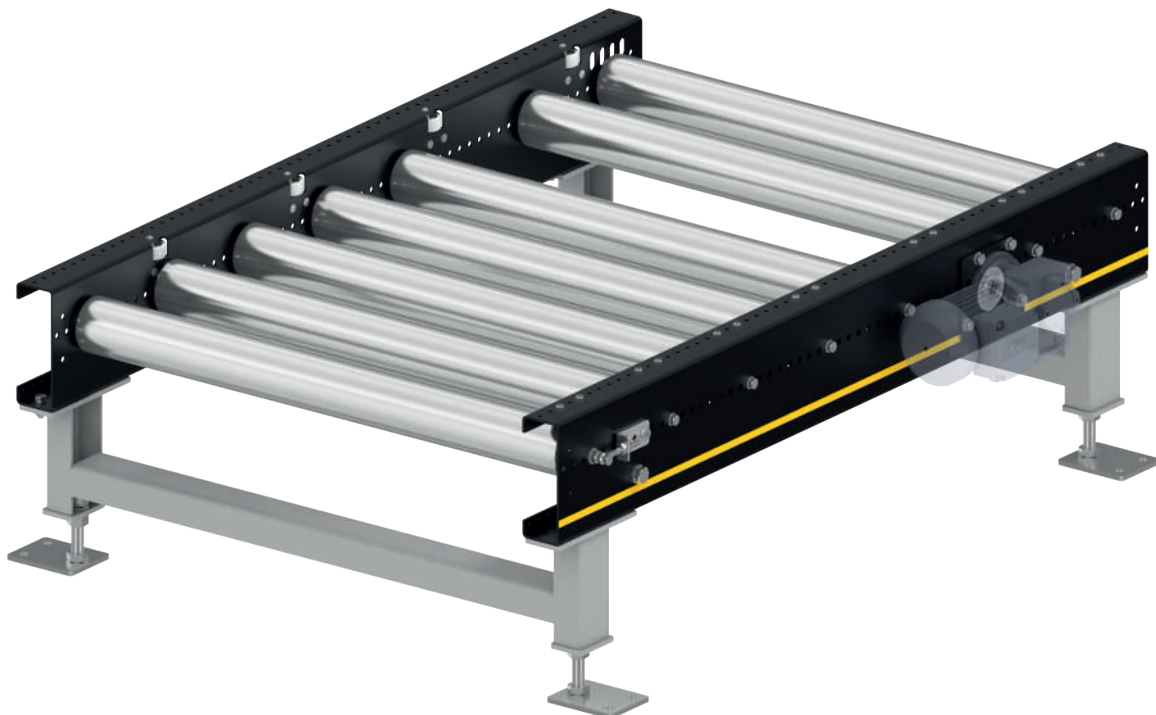

Technical data

General technical data	
Max. load capacity	1000 kg/m
Conveyor speed	0.1 to 0.5 m/s
Ambient temperature	-28 °C to +45 °C (non-condensing) Note: Deep freeze applications are possible only as an option
Incline/decline	Up to max. 4% (for certain motor variants only)
Drive	
Rated voltage	400 V
Motor type	Gear motor
Power	0.12 to 0.75 kW
Roller chain	5/8" x 3/8"
Roller	
Roller type	Interroll Series 3950
Roller diameter	89 mm
Sprocket	Z18
Wall thickness of rollers	3 or 5 mm
Material	Steel, zinc-plated
Profile	
Mounting hole pitch	25 mm
Dimensions	200 x 70 x 4 mm
Color	Powder-coated, all RAL colors are possible
Material	Steel

ROLLER CONVEYOR PM 9710

Dimensions

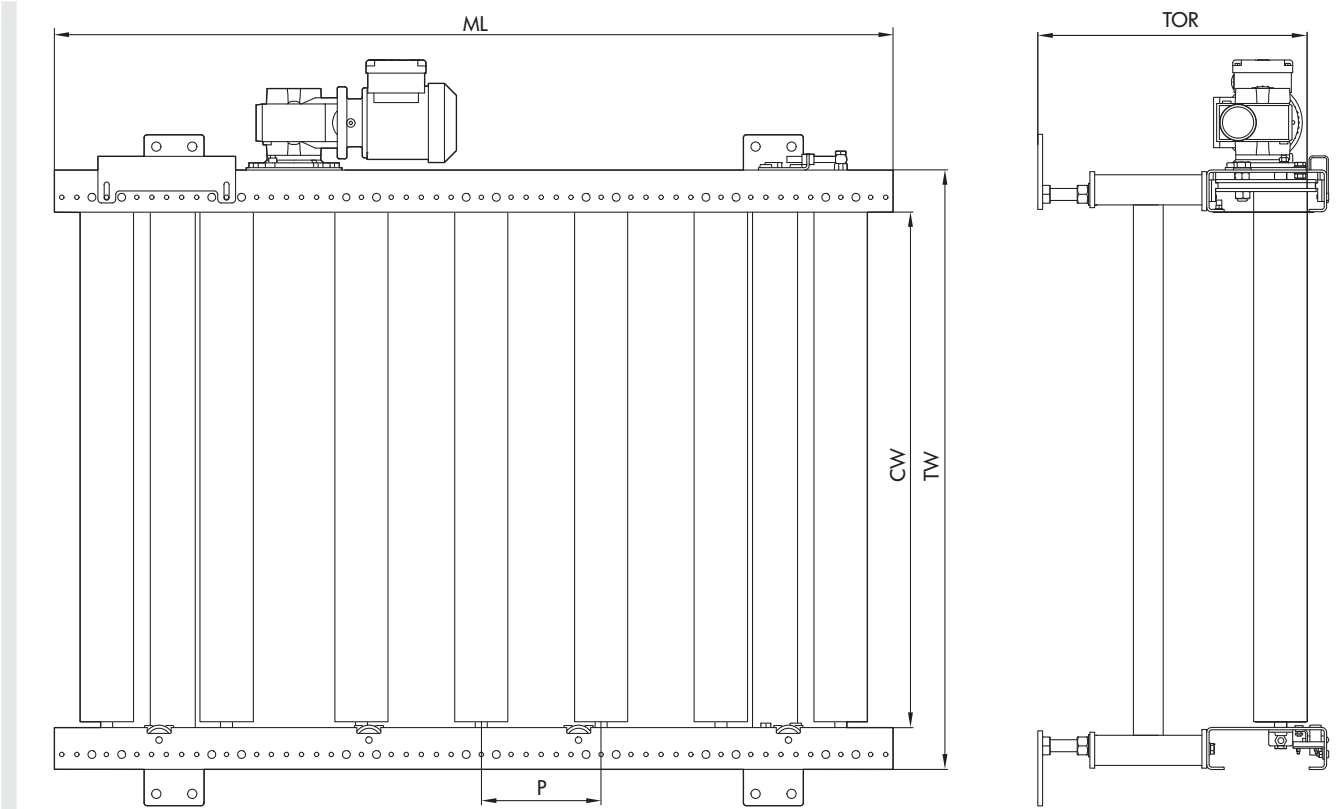

Conveying good width (CGW)	800, 1000, 1200 mm
Module conveying width (CW)	860, 1060, 1260 mm
Module width (TW)	1000, 1200, 1400 mm
Conveying height (TOR)	170 to 1200 mm
Roller pitch (P)	175 to 250 mm
Module length (ML)	750 to 5960 mm

ROLLER CONVEYOR PM 9710



ROLLER CONVEYOR PM 9711



Product description

The roller conveyor is suited for horizontal transport of full and empty pallets. Tensioning of the chains is not required because of the chain transmission from roller to roller. At the same time, the rigid frame profile serves as side guide. Floor irregularities can easily be compensated with adjustable supports.

The use of the Interroll Pallet Drive allows a compact design. Since the drive is located within the side profiles, the individual modules can be installed very close to each other. Together with MultiControl and Pallet Control, it is very easy to implement a zero-pressure accumulation conveyor.

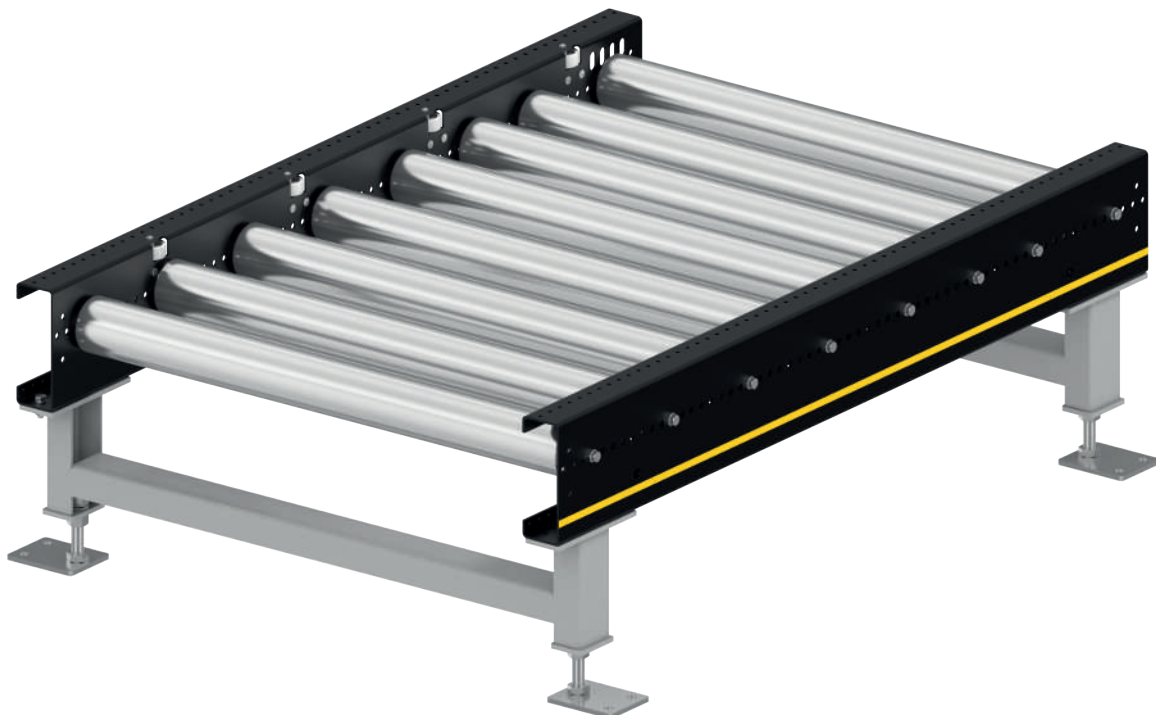

Technical data

General technical data	
Max. load capacity	1000 kg/m
Conveyor speed	0.22 m/s
Ambient temperature	-5 °C to +45 °C (non-condensing) Note: Deep freeze applications are possible only as an option
Incline/decline	Up to max. 4% (for certain motor variants only)
Drive	
Rated voltage	400 V
Motor type	Pallet Drive
Power	0.07 kW
Roller chain	5/8" x 3/8"
Rollers	
Roller type	Interroll Series 3950
Roller diameter	89 mm
Sprocket	Z18
Wall thickness of rollers	3 mm or 5 mm
Material	Steel, zinc-plated
Profile	
Mounting hole pitch	31.75 mm
Dimensions	200 x 70 x 4 mm
Color	Powder-coated, all RAL colors are possible
Material	Steel

ROLLER CONVEYOR PM 9711

Dimensions

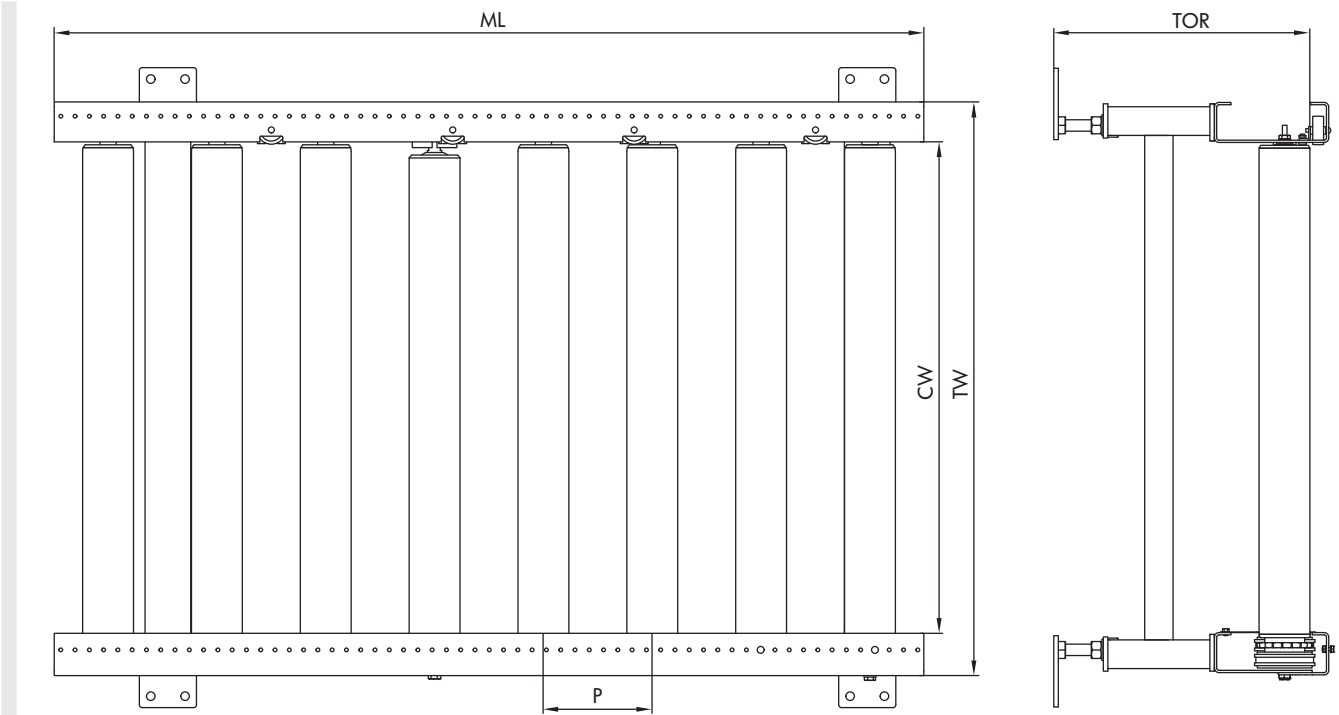

Conveying good width (CGW)	800, 1000, 1200 mm
Module conveying width (CW)	860, 1060, 1260 mm
Module width (TW)	1000, 1200, 1400 mm
Conveying height (TOR)	170 to 1200 mm
Roller pitch (P)	127 to 254 mm
Module length (ML)	300 to 5960 mm

ROLLER CONVEYOR PM 9711



ROLLER CONVEYOR PM 9712



Product description

The roller conveyor is suited for horizontal transport of full and empty pallets. The drive is implemented using a 48-V RollerDrive that is connected to a fixed number of idlers via PolyVee belts. Since the drive is located within the side profiles, the individual modules can be installed very close to each other. This allows for a very compact design.

At the same time, the rigid frame profile serves as side guide. Floor irregularities can easily be compensated with adjustable supports.

Together with MultiControl, it is very easy to implement a zero-pressure accumulation conveyor.

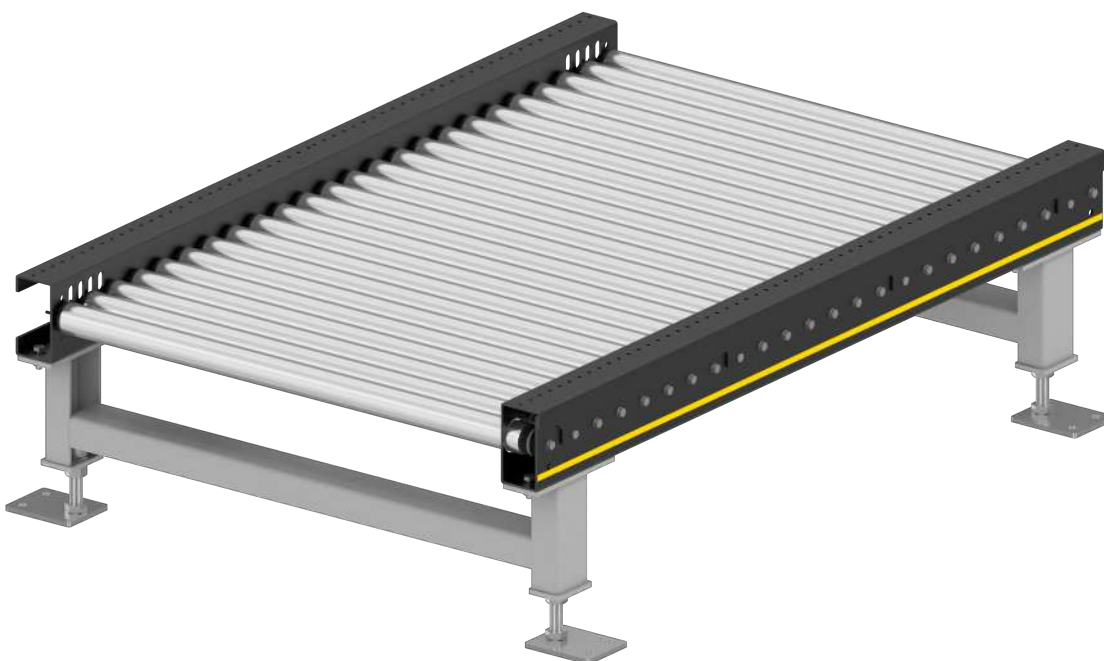

Technical data

General technical data	
Max. load capacity	200 kg/m
Conveyor speed	0.22 m/s
Ambient temperature	0 °C to +40 °C (non-condensing) Note: Deep freeze applications are possible only as an option
Incline/decline	Up to max. 4 % (for certain motor variants only)
Drive	
Rated voltage	48 V
Motor type	RollerDrive EC 5000
Power	0.05 kW
Torque transmission	PolyVee belt
Rollers	
Roller type	Interroll Series 3500
Roller diameter	60 mm
Wall thickness of rollers	2 mm
Material	Steel, zinc-plated
Profile	
Mounting hole pitch	20 mm
Dimensions	132 x 70 x 4 mm
Color	Powder-coated, all RAL colors are possible
Material	Steel

ROLLER CONVEYOR PM 9712

Dimensions

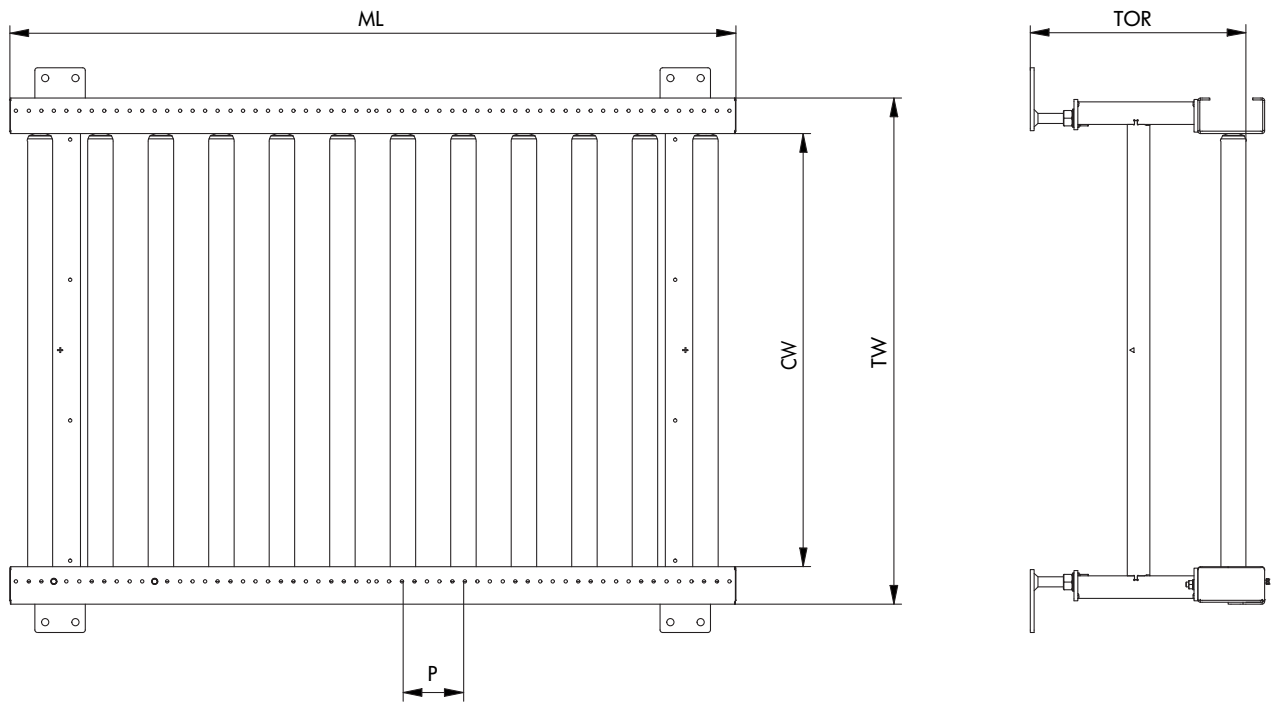

Conveying good width (CGW)	800, 1000, 1200 mm
Module conveying width (CW)	860, 1060, 1260 mm
Module width (TW)	1000, 1200, 1400 mm
Conveying height (TOR)	95 to 1200 mm
Roller pitch (P)	80 to 120 mm
Module length (ML)	240 to 2160 mm

ROLLER CONVEYOR PM 9712



ROLLER CONVEYOR PM 9715



Product description

The roller conveyor is particularly suited for GMA pallets, but also for other pallet types for horizontal transport of full and empty pallets. The rollers can be relocated quickly due to the tangential drive principle and frame design.

The chain tensioning station on the outside allows for easy re-tensioning of the precision roller chain. The drive can be installed on the right side or optionally on the left in the direction of travel (DOT). Floor irregularities can easily be compensated with adjustable supports.

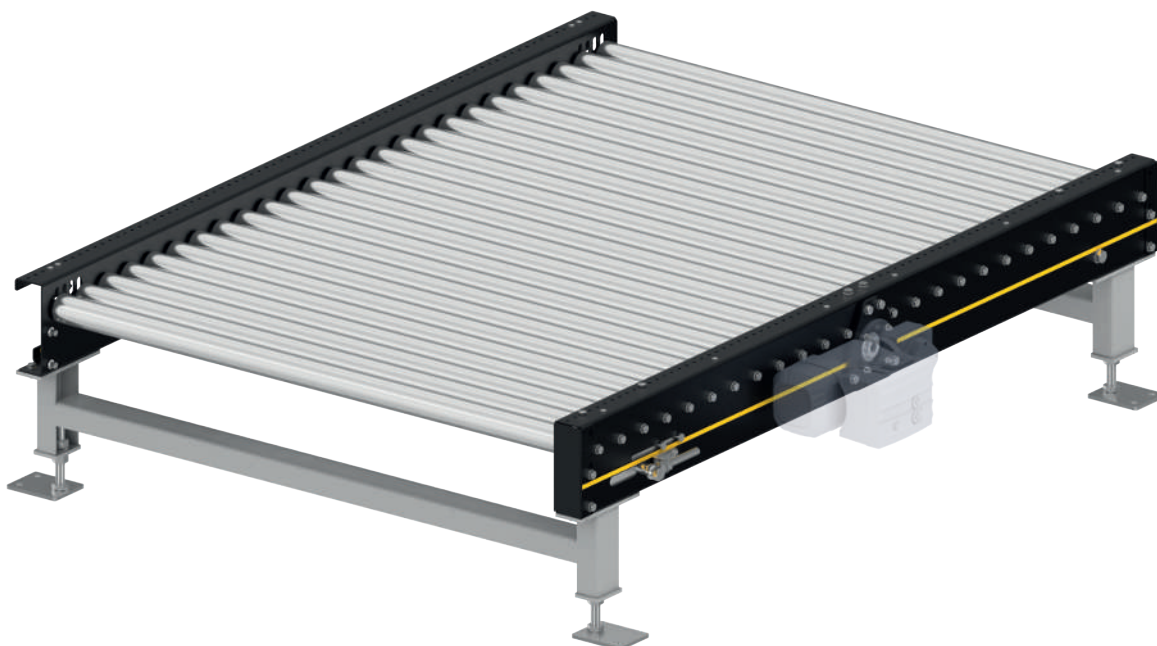

Technical data

General technical data	
Max. load capacity	1000 kg/m
Conveyor speed	0.1 to 0.5 m/s
Ambient temperature	-28 °C to +45 °C (non-condensing) Note: Deep freeze applications are possible only as an option
Incline/decline	Up to max. 4% (for certain motor variants only)
Drive	
Rated voltage	400 V
Motor type	Gear motor
Power	0.12 to 0.75 kW
Roller chain	5/8" x 3/8"
Rollers	
Roller type	Interroll Series 3500
Roller diameter	60 mm
Sprocket	Z13
Material	Steel, zinc-plated
Wall thickness of rollers	3 mm
Profile	
Dimensions	200 x 70 x 4 mm
Color	Powder-coated, all RAL colors are possible
Material	Steel

ROLLER CONVEYOR PM 9715

Dimensions

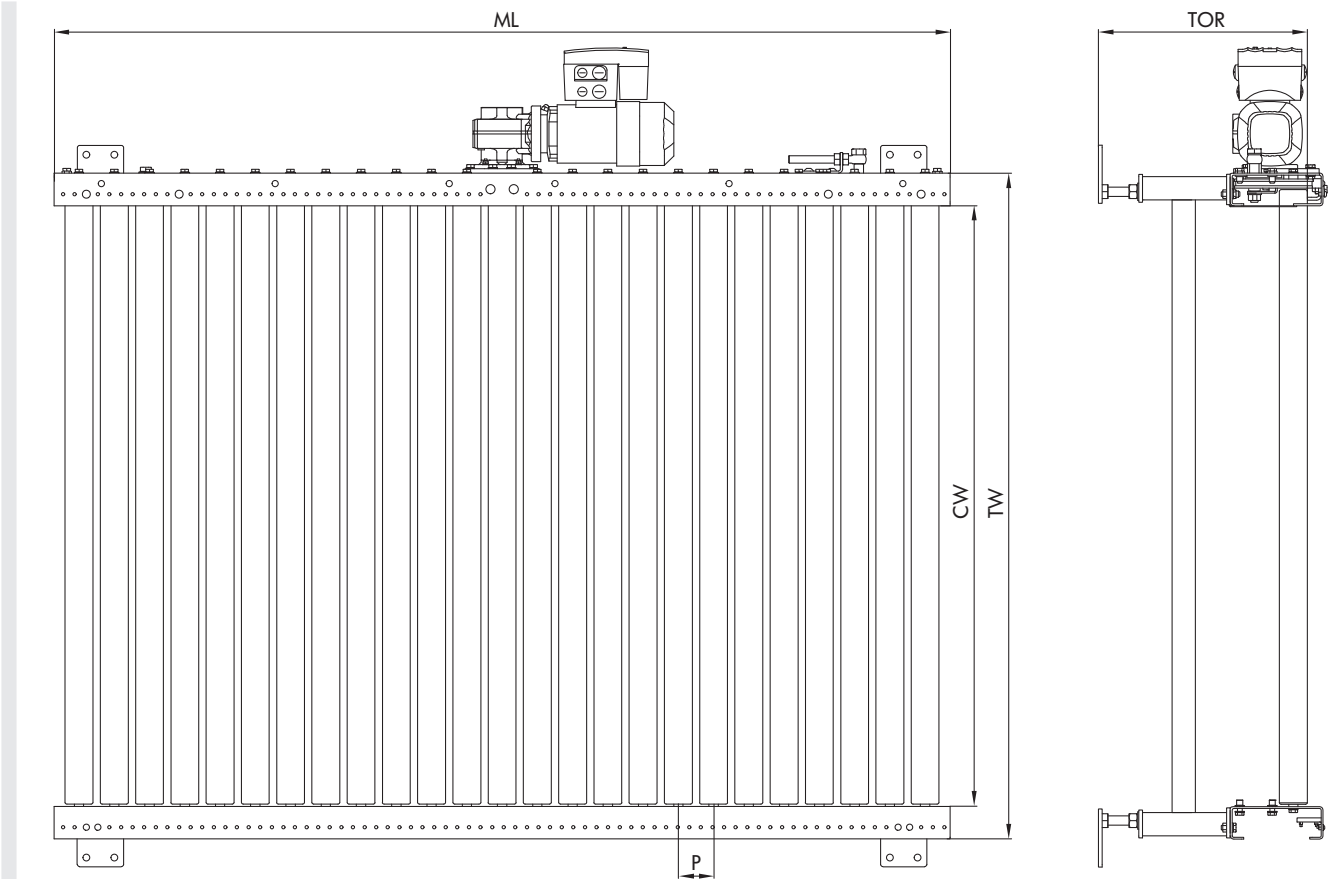

Conveying good width (CGW)	1216 mm
Module conveying width (CW)	1276 mm
Module width (TW)	1500 mm
Conveying height (TOR)	170 to 1200 mm
Roller pitch (P)	76 mm
Module length (ML)	400 to 5960 mm

ROLLER CONVEYOR PM 9715



CHAIN CONVEYOR PM 9720



Product description

The chain conveyors are suited for horizontal transport of full and empty pallets. For each chain run, a duplex precision roller chain with straight links is used as a transport chain. The transport chain is guided in a plastic chain guide. The integrated tensioning station with 180° wrap allows for easy re-tensioning of the chain.

The drive station is arranged between the runs. Floor irregularities can easily be compensated with adjustable supports.

The module is available with two or three chain runs. If bagged materials or bulk cargo, poor pallet quality or weights of more than 1000 kg are being handled, we recommend using a chain conveyor with three chain runs.

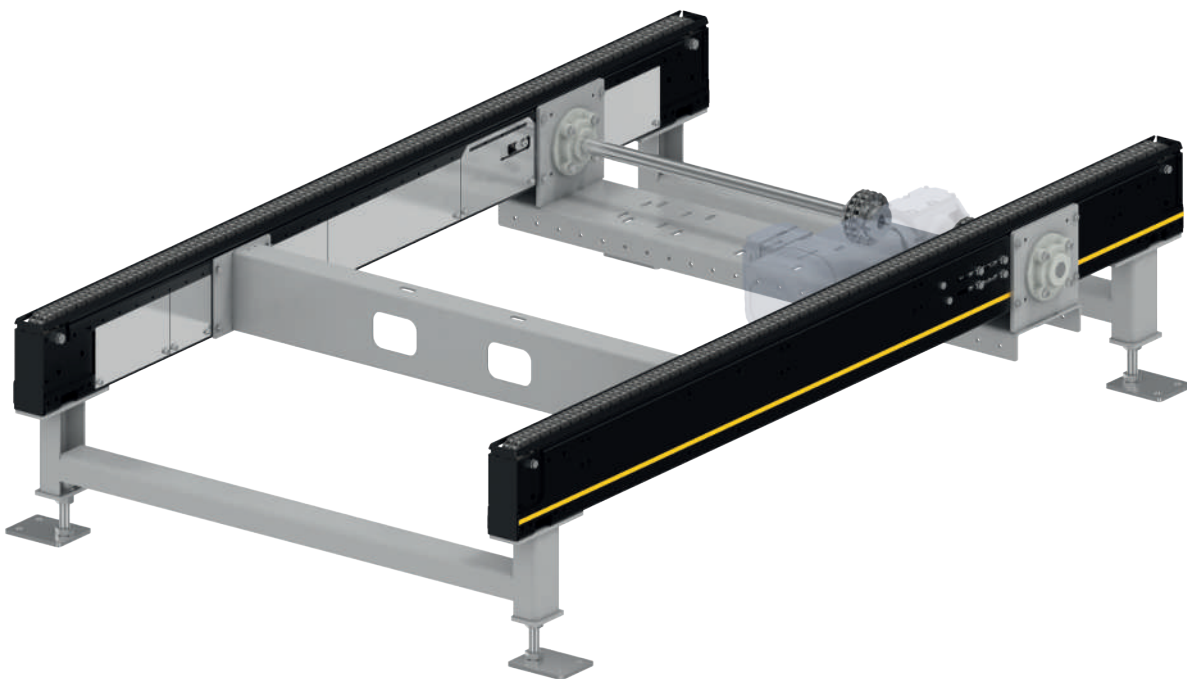

Technical data

General technical data	
Max. load capacity	1500 kg/m
Conveyor speed	0.1 to 0.5 m/s
Ambient temperature	-28 °C to +45 °C (non-condensing) Note: Deep freeze applications are possible only as an option
Incline/decline	Up to max. 4% (for certain motor variants only)
Number of chains	2 or 3
Drive	
Rated voltage	400 V
Motor type	Gear motor
Power	0.25 to 2.0 kW
Roller chain	5/8" x 3/8" duplex with straight bracket joints
Profile	
Dimensions	155 x 72 x 4 mm
Color	Powder-coated, all RAL colors are possible
Material	Steel

CHAIN CONVEYOR PM 9720

Dimensions

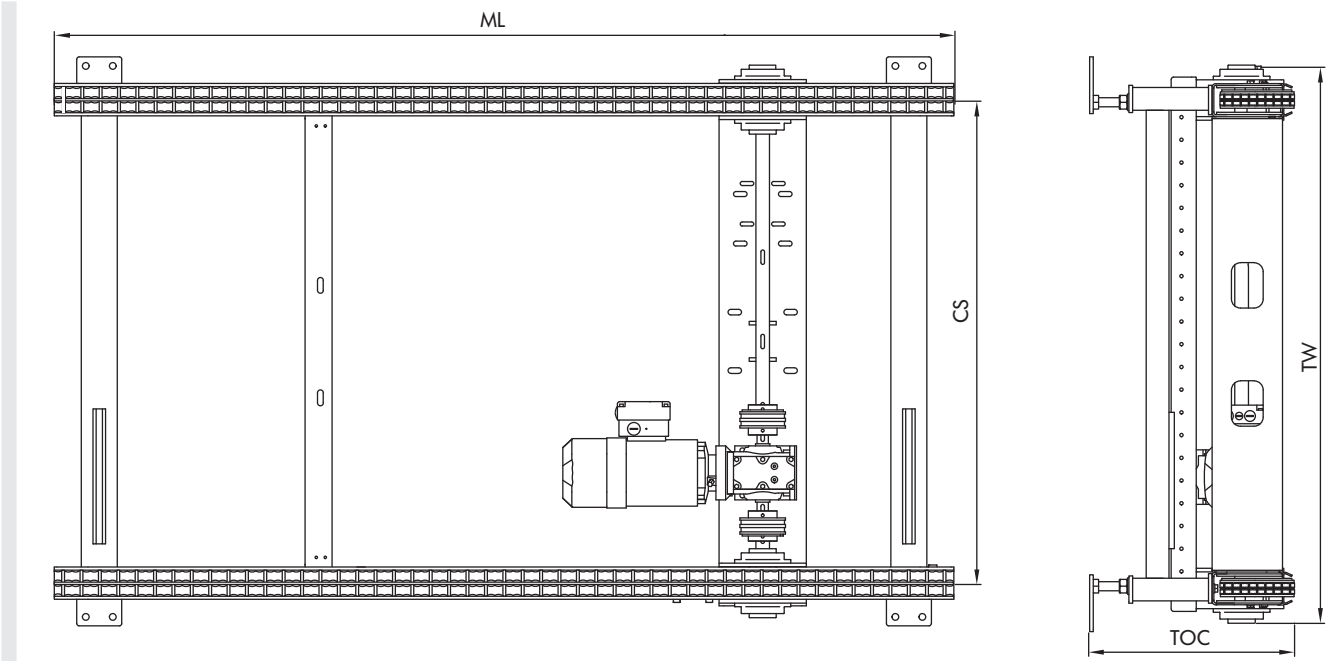

Conveying good width (CGW)	850, 1000, 1200 mm
Module width (TW)	755, 905, 1230 mm
Chain spacing (CS)	600, 750, 1075 mm
Conveying height (TOC)	200 to 1200 mm
Module length (ML)	1200 to 5600 mm

CHAIN CONVEYOR PM 9720



CHAIN TRANSFER PM 9730



Product description

The chain transfer is used for 90° change of direction for horizontal transport of full and empty pallets. For each chain run, a duplex precision roller chain with straight links is used as a transport chain.

The transport chains are guided in plastic chain guides. Compact transfer to the subsequent conveyor is possible to a low deflection radius of only 43 mm. The integrated tensioning station with 180° wrap allows for easy re-tensioning of the chain.

The drive station of the transport chains is positioned between the runs under the track. The parallel lift occurs electrically and is supported with maintenance-free ball bearings. Floor irregularities can easily be compensated with adjustable supports.

The module is available with two or three chain runs. If bagged materials or bulk cargo, poor pallet quality or weights of more than 1000 kg are being handled, we recommend using a chain conveyor with three chain runs.

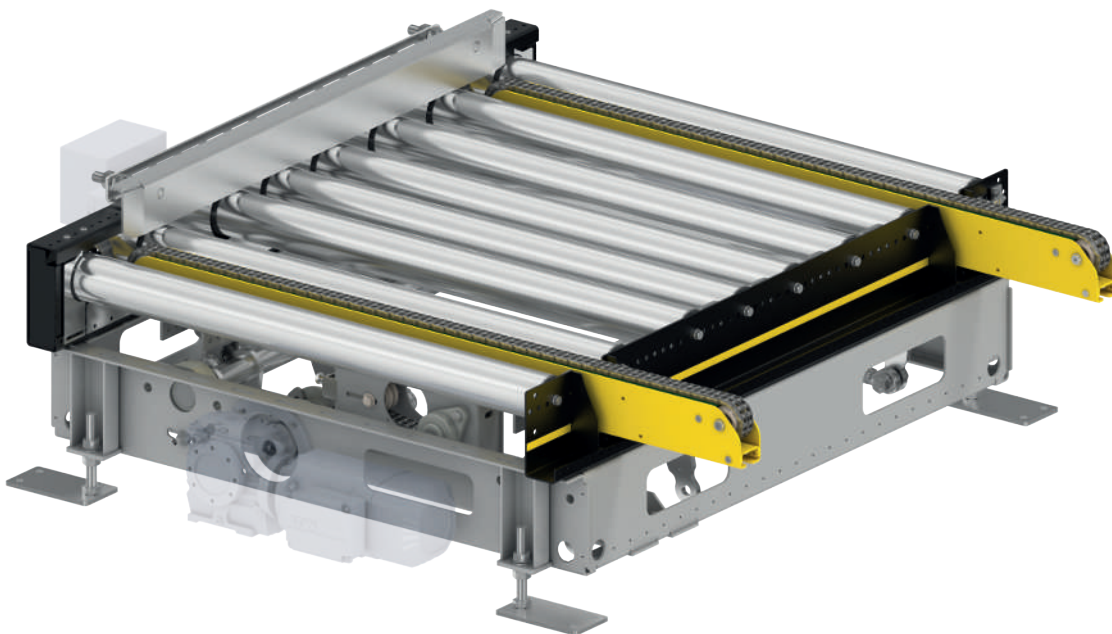

Technical data

General technical data	
Max. load capacity	1000 kg/m
Conveyor speed	0.1 to 0.5 m/s
Max. stroke height	30 mm
Stop positions	2
Ambient temperature	-28 °C to +45 °C (non-condensing) Note: Deep freeze applications are possible only as an option
Incline/decline	Not suitable
Number of chains	2 or 3
Chain conveyor drive	
Rated voltage	400 V
Motor type	Gear motor
Power	1.1 kW
Roller chain	5/8" x 3/8" duplex with straight bracket joints
Roller conveyor drive	
Rated voltage	400 V
Motor type	Gear motor
Power	0.12 to 0.55 kW
Roller chain	5/8" x 3/8"
Drive stroke	
Rated voltage	400 V
Motor type	Gear motor
Power	0.55 kW
Roller chain	1"
Rollers	
Roller type	Interroll Series 3950
Wall thickness of rollers	3 or 5 mm
Material	Steel, zinc-plated
Profile	
Dimensions	200 x 70 x 4 mm
Color	Powder-coated, all RAL colors are possible
Material	Steel

CHAIN TRANSFER PM 9730

Dimensions

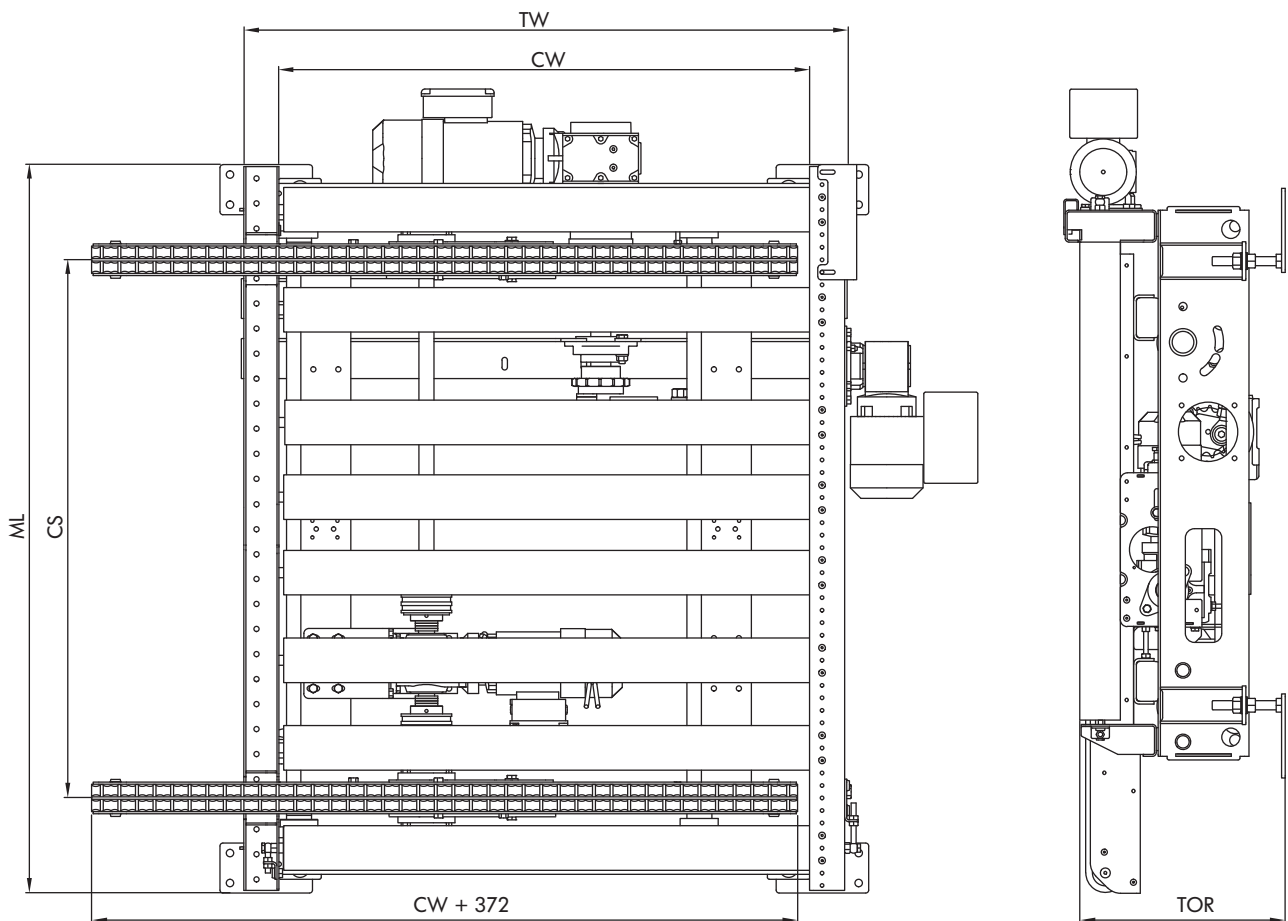

Conveying good width (CGW)	850, 1000, 1200 mm
Module conveying width (CW)	860, 1060, 1260 mm
Module width (TW)	1000, 1200, 1400 mm
Chain spacing (CS)	1075 mm
Conveying height (TOR)	350 to 1200 mm
Module length (ML)	1400 mm



ROLLER TRANSFER PM 9732



Product description

The roller transfer is used for 90° change of direction for horizontal transport of full and empty pallets. The rigid frame profiles of the roller conveyor are coated in the desired RAL color. The roller conveyor drive is available installed on the right side or optionally on the left of the track in the direction of travel (DOT). The force is transmitted via 5/8" x 3/8" precision roller chain.

A solid steel profile frame serves as lifting frame for eccentric lifting cams on ball bearings. The parallel lift occurs electrically and is supported with maintenance-free ball bearings. Floor irregularities can easily be compensated with adjustable supports.



Technical data

General technical data	
Max. load capacity	1000 kg/m
Conveyor speed	0.1 to 0.5 m/s
Max. stroke height	60 mm
Stop positions	3
Ambient temperature	-28 °C to +45 °C (non-condensing) Note: Deep freeze applications are possible only as an option
Incline/decline	Not suitable
Roller conveyor drive	
Rated voltage	400 V
Motor type	Gear motor
Power	0.37 kW
Roller chain	5/8" x 3/8"
Drive stroke	
Rated voltage	400 V
Motor type	Gear motor
Power	0.55 kW
Roller chain	1"
Rollers	
Roller type	Interroll Series 3950
Wall thickness of rollers	3 or 5 mm
Material	Steel, zinc-plated
Profile	
Dimensions	200 x 70 x 4 mm
Color	Powder-coated, all RAL colors are possible
Material	Steel

ROLLER TRANSFER PM 9732

Dimensions

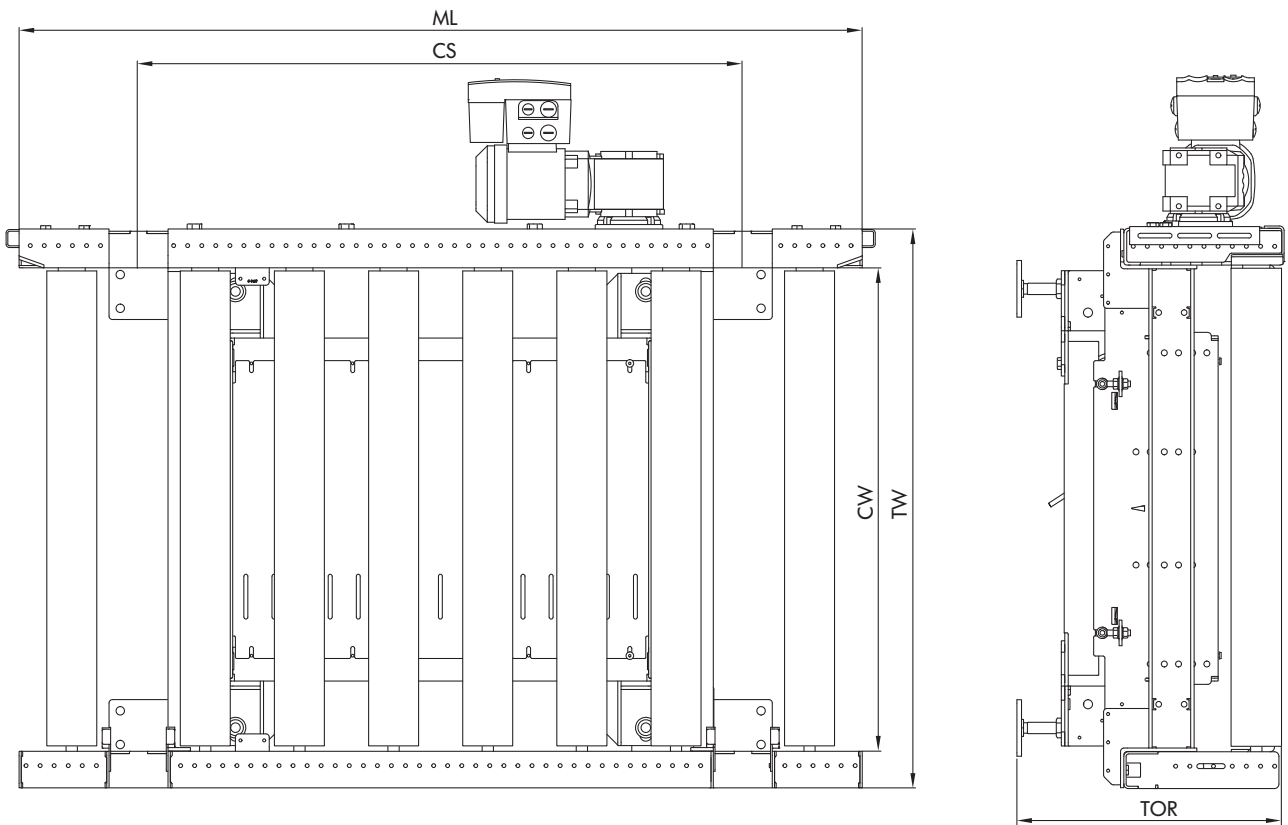

Conveying good width (CGW)	800, 1000, 1200 mm
Module conveying width (CW)	860, 1060, 1260 mm
Module width (TW)	1000, 1200, 1500 mm
Chain spacing (CS)	1075 mm
Conveying height (TOR)	500 to 1200 mm
Module length (ML)	1500 mm

ROLLER TRANSFER PM 9732



TURNTABLE PM 9735



Product description

The turntable is used for change of direction or for turning full and empty pallets. The turn can measure between 0° and 270°. The efficient turning motion is realized using a precision roller chain, with drive transmitted from a sprocket connected directly to the motor shaft.

The efficient turning motion is managed using a robust ball steering ring. The chain tensioning station of the rollers located on the outside allows easy retensioning of the drive chain. The drive of the roller conveyor is installed on the right side or optionally on the left in the direction of travel (DOT). Floor irregularities can easily be compensated with adjustable supports.

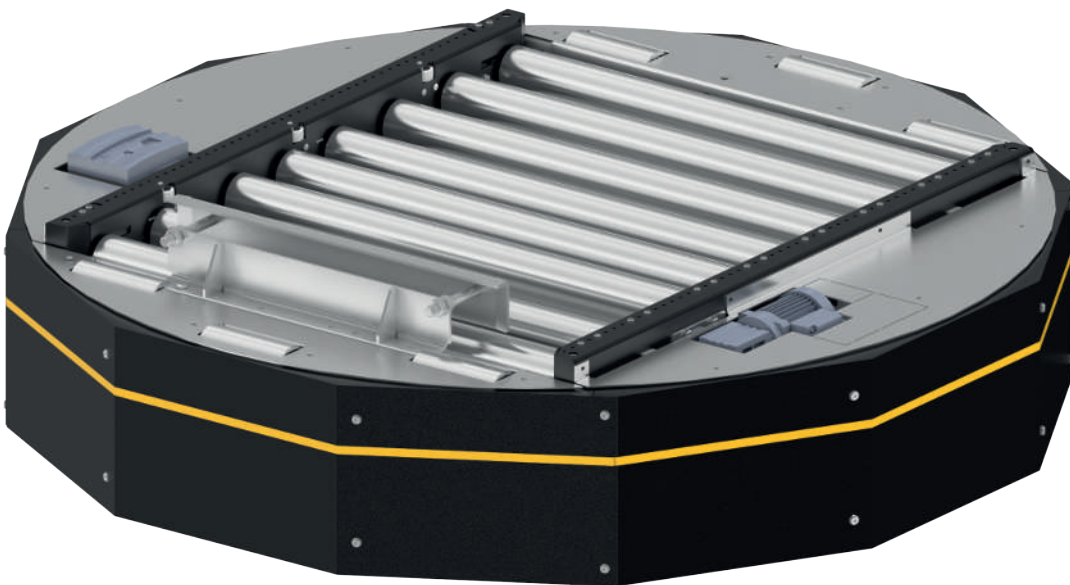

Technical data

General technical data	
Max. load capacity	1000 kg/m
Conveyor speed	0.1 to 0.5 m/s
Rotational speed (V)	90° in 4 s
Ambient temperature	-28 °C to +45 °C (non-condensing) Note: Deep freeze applications are possible only as an option
Incline/decline	Not suitable
Roller conveyor drive	
Rated voltage	400 V
Power	0.12 to 0.75 kW
Roller chain	5/8" x 3/8"
Turntable drive	
Rated voltage	400 V
Motor type	Gear motor
Power	0.37 kW
Roller chain	5/8" x 3/8"
Rollers	
Roller type	Interroll Series 3950
Roller diameter	89 mm
Sprocket	Z18
Wall thickness of rollers	3 or 5 mm
Material	Steel, zinc-plated
Profile	
Dimensions	200 x 70 x 4 mm
Color	Powder-coated, all RAL colors are possible
Material	Steel

TURNTABLE PM 9735

Dimensions

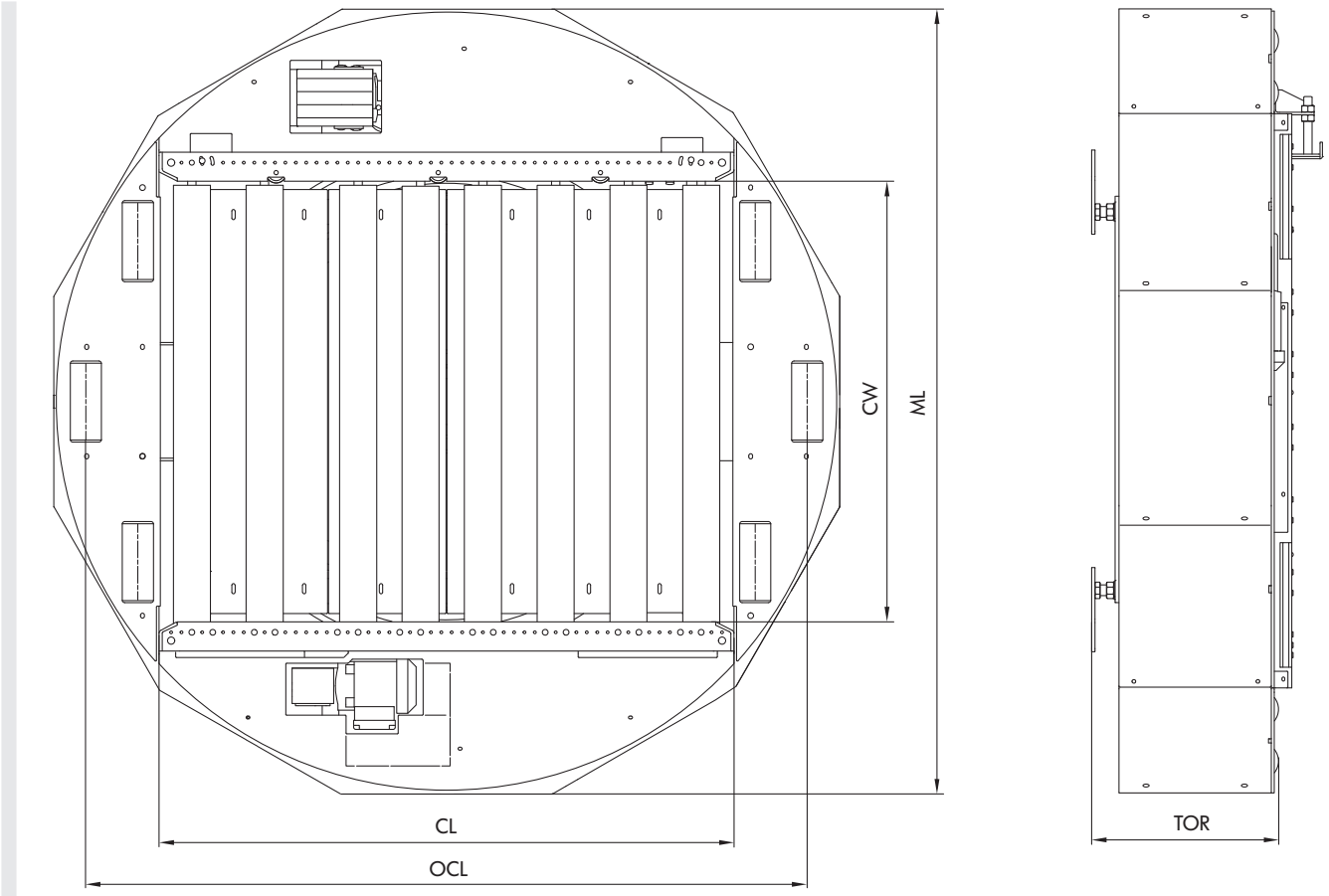

Conveying good width (CGW)	800, 1000 mm
Module conveying width (CW)	1060 mm
Conveying height (TOR)	350 to 1200 mm
Conveyor length (CL)	1380 mm
Overall conveyor length (OCL)	1740 mm
Module length (ML)	1890 mm



TURNTABLE PM 9737



Product description

The turntable is used for change of direction or for turning full and empty pallets. The turn can measure between 0° and 270° . The efficient turning motion is realized using a precision roller chain, with drive transmitted from a sprocket connected directly to the motor shaft.

The efficient turning motion is managed using a robust ball steering ring. The chain tensioning station of the rollers located on the outside allows easy retensioning of the drive chain. The drive of the roller conveyor is installed on the right side or optionally on the left in the direction of travel (DOT). Floor irregularities can easily be compensated with adjustable supports.

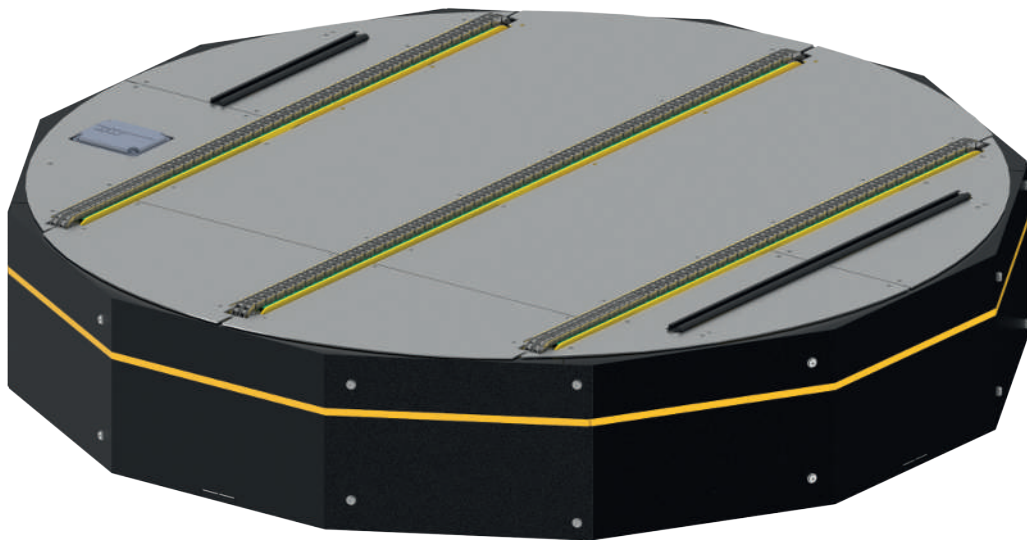

Technical data

General technical data	
Max. load capacity	1500 kg/m
Conveyor speed	0.1 to 0.5 m/s
Rotational speed (V)	90° in 4 s
Ambient temperature	-28 °C to +45 °C (non-condensing) Note: Deep freeze applications are possible only as an option
Incline/decline	Not suitable
Chain conveyor drive	
Rated voltage	400 V
Power	0.12 to 0.75 kW
Roller chain	5/8" x 3/8" duplex with straight bracket joints
Turntable drive	
Rated voltage	400 V
Motor type	Gear motor
Power	0.37 kW
Roller chain	5/8" x 3/8"
Profile	
Dimensions	200 x 70 x 4 mm
Color	Powder-coated, all RAL colors are possible
Material	Steel

TURNTABLE PM 9737

Dimensions

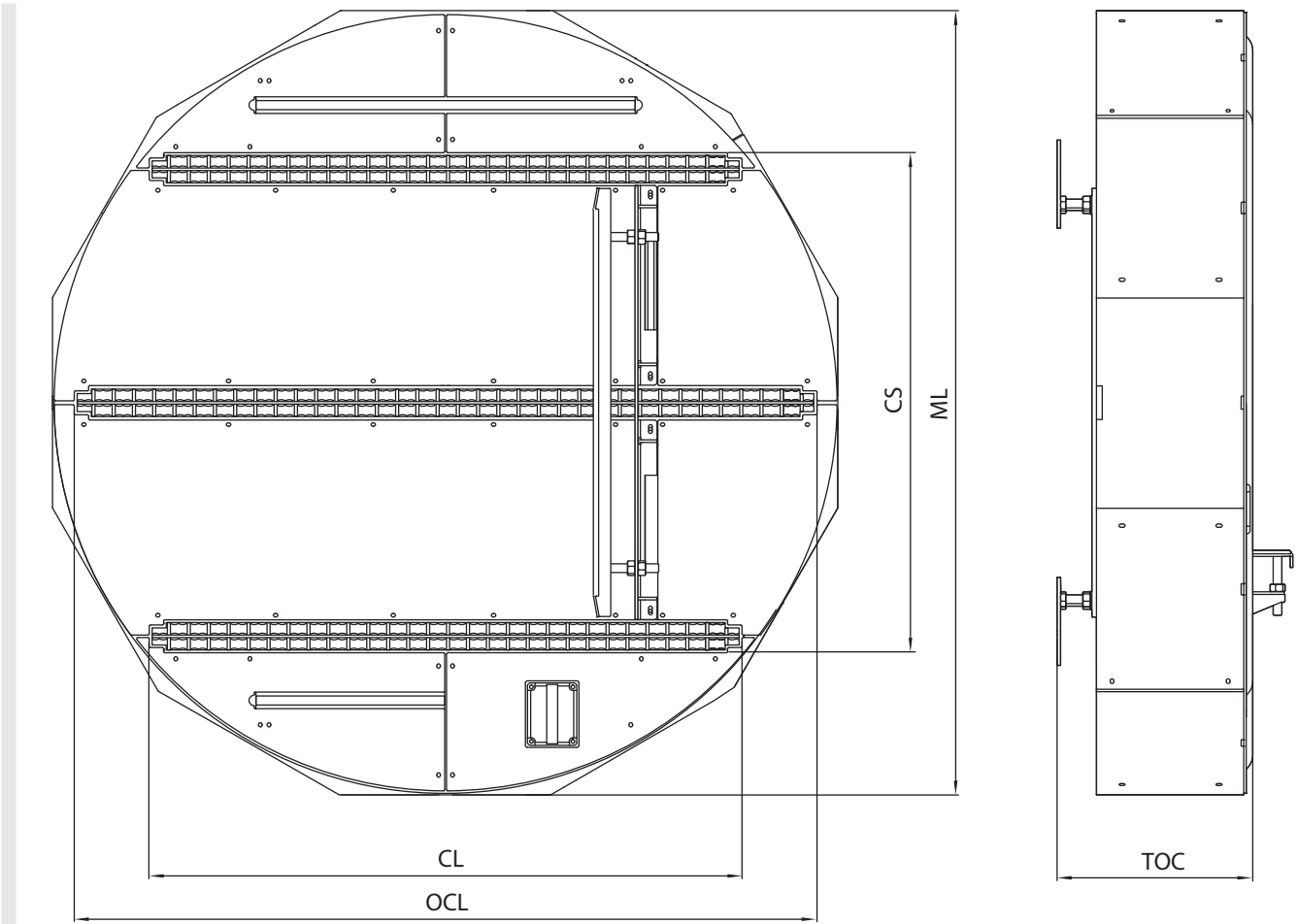

Conveying good width (CGW)	850, 1000, 1200 mm
Chain spacing (CS)	1075 mm
Conveying height (TOC)	350 to 1200 mm
Conveyor length (CL)	1360 mm
Overall conveyor length (OCL)	1740 mm
Module length (ML)	1890 mm

INTERROLL STACKER CRANE PM 9770



The Interroll Stacker Crane is the ideal solution for automated pallet handling and the perfect addition to the MPP and Pallet Flow solutions from Interroll.

The compact stacker crane provides a highly dynamic flow storage system - achieving a high pallet turnover and optimal utilization of space. Passages for forklifts are completely omitted. The lightweight construction and integrated energy recovery make the stacker crane extremely energy-efficient.

The stacker crane is equipped with a roller conveyor which stores and removes pallets in less than four seconds. The proven mechanical interface between stacker crane and flow storage system increases availability and safety of the entire system.

Safety and accuracy play an important role in highly dynamic applications. Interroll's stacker crane is equipped with 180° sensors and inspects precisely whether the intended pick-up station is empty or not. Centering the pallet is done automatically so that it can be transferred exactly in the middle of the lane. This ensures the high degree of availability and avoids damages to goods or the system. The integrated lifting speed control and powerful braking systems ensure a high level of safety, even at a speed of up to three meters per second.

Thanks to the modular and pre-assembled design of the construction, the low-maintenance stacker crane can be delivered and assembled with ease.



INTERROLL STACKER CRANE PM 9770

Technical data

General technical data	
Max. load capacity	1000 kg
Lane length	max. 95 m
Pallet type	EUR EPAL
Lower startup dimension	0.5 m
Upper startup dimension	max. 9.8 m
Drive	
Travel drive	Gear motor for all shafts
Power	max. 15 kW
Speed	max. 3 m/s
Acceleration	max. 1 m/s ²
Lifting capacity	max. 15 kW
Lifting speed	max. 0.8 m/s
Stroke acceleration	max. 0.8 m/s ²
Dimensions	
Overall height	12 m
Overall length	3.1 m

TRANSFER CAR PM 9750



Product description

The Interroll Transfer Car is the perfect solution for loading and unloading full or empty pallets at picking stations and pallet storage slots, branch tracks as well as Interroll dynamic flow storage racks. Up to 5 meters per second can be achieved, allowing even large distances to be bridged quickly and reliably, for example in the area of route preparation or the connection between warehouse and production.

The highly dynamic transfer car weighs just 275 kilograms and, thanks to the intelligent drive concept, does not require a movable control cabinet for the electrical connection. The running gear consists of steel profiles screwed together, which are powder-coated in RAL 1021 - signal yellow.

The energy supply of the transfer car is provided via bus bar. Lateral, adjustable guide rollers at the transfer carriages ensure an absolute directional stability at higher speeds. Durable and wear-resistant Vulkollan wheels ensure very smooth running and reliable vibration dampening.

The transfer car is particularly designed for the combination with Interroll flow storage systems. The perfectly matched interface ensures a high degree of availability of the system while also providing a high level of safety.



Technical data

General technical data	
Max. load capacity	1000 kg
Lane length	max. 95 m
Pallet type	EUR EPAL
Travel height	min. 0.28 m
Drive	
Drive	Gear motor
Power	max. 15 kW
Speed	max. 5 m/s
Acceleration	max. 1 m/s ²

CONTROLS

PALLET CONTROL PC 6000



Product description

The intelligent control unit serves as a link between the 400 V AC Pallet Drive and Interroll's proven 24 V MultiControl, which provides the complete logic for zero-pressure-accumulation conveyors. However, this solution eliminates the need for centralized PLC cabling and PLC programming.

The integrated soft start function reduces the starting torque, which relieves the load on all mechanical components. This in turn provides optimum pallet acceleration. Pallet overrun after the Pallet Drive has been switched off is also regulated by Pallet Control.

The control offers many functions and supports preventive maintenance. The Pallet Control Configurator, which can be downloaded from the Interroll website, allows to easily change parameters or modify the direction of rotation via the USB connection of the Pallet Control, without having to move and replug cables. Current and power can be monitored and the current status is displayed. In addition, the total operating time of the respective Pallet Drive is displayed, which allows to preventively arrange the necessary maintenance. This reduces maintenance requirements and possible downtimes to a minimum.

A thermal controller contact and continuous analysis of current consumption protect the Pallet Drive against overload. The optional brake in the Pallet Drive is also activated via Pallet Control. Alternatively, Pallet Control can be activated via other 24 V digital inputs or a 0–10 V DC analogue input.



Technical data

	Pallet Control
Rated voltage	3 x 400 V AC 50 Hz; 24 V DC
Voltage range	380 – 420 V AC 50 Hz; 22 – 26 V DC
Current consumption	Max. 3 A @ 400 V AC; max. 2 A @ 24 V DC Max. 10 A @ 400 V AC; max. 2 A @ 24 V DC
Protection rate	IP54
Weight	0.5 kg
Ambient temperature in operation	–28 °C to +40 °C (–22 °F to +104 °F)
Ambient temperature during transport and storage	–40 °C to +80 °C (–40 °F to +176 °F)
Max. temperature change	1 K/min, 3 h, 2 cycles
Max. relative humidity	93 % at +40 °C (+104 °F), 14 days, non-condensing
Max. installation height above sea level	1000 m. Installation in systems at an altitude above 1000 m (3300 ft) is possible in principle. However, this may result in lower performance values.

CONTROLS

MULTICONTROL AI

For EC5000 24 V, 48 V
20 W, 35 W, 50 W with analog interface



Application area

Zero-pressure accumulation conveying (ZPA) for systems with medium to high number of conveyor zones. Control of the Interroll Transfer and High Performance Divert as well as Interroll Pallet Drive (via Pallet Control).

Product description

The MultiControl is a four-zone control. This means that up to four RollerDrive EC5000 AI and four zone sensors can be connected. The use of Y-cables enables connecting four additional inputs or outputs. The connections can be configured individually.

MultiControl is multi-protocol-capable. PROFINET, EtherNet/IP and EtherCat can be used via simple switching.

With help of the MultiControl, sensors and RollerDrive are directly integrated into the field bus level. An additional sensor/actuator level and, as a result, additional communication lines or a gateway become redundant. A standard flat cable is used for power supply. They can simply be cut to the desired length and can be connected very quickly using the piercing technology of MultiControl.

The separate voltage supply allows a safe power-off of the RollerDrive while the bus communication and sensors can continue to be used.

Addressing and naming is done over PLC software, a web user interface, or with the Interroll teach-In method. With the Teach-In method, automatic addressing and configuration of all MultiControl is possible. In addition, the sequence of all MultiControls in the conveyor line can be determined. This saves time during the commissioning on site.



CONTROLS MULTICONTROL AI

For EC5000 24 V, 48 V
20 W, 35 W, 50 W with analog interface

Functions

- Easy handling – One control card for PROFINET, EtherNet/IP and EtherCat (simple toggling of bus protocols)
- Independent power supply for RollerDrive
- Plug & Play in case of replacements – no addressing or configuration required
- Status display with LEDs for all functions and I/Os
- Integrated logic for zero-pressure accumulation conveying incl. initialization
- Secure communication with the use of certificates: PROFINET Conformance Class B, EtherNet/IP ODVA Conformance, EtherCat Conformance
- Configuration via PLC, web browser menu and via teach-In method of:
 - Speed, direction of rotation, start and stop ramp of RollerDrive
 - Sensor properties
 - Timer
 - Error handling
 - Logic (single/train release)
- UL-listed
- Voltage limitation via brake chopper
- Variable process images for optimizing the data volumes transferred between MultiControl and PLC
- Functional ground connection for shield of communication line
- Polarity reversal protection of voltage supply
- Short circuit-proof design of voltage supply of inputs and outputs

Possible applications

Use of a PLC	Function of a PLC	Function of MultiControl
No	<ul style="list-style-type: none"> • None 	<ul style="list-style-type: none"> • Implementation of ZPA logic
Yes	<ul style="list-style-type: none"> • Influencing the ZPA logic • Tracking of conveying goods • Error diagnostics 	<ul style="list-style-type: none"> • Implementation of ZPA logic • Implementation of PLC specifications
Yes	<ul style="list-style-type: none"> • The PLC must be programmed and controls all connected RollerDrive via this program • Tracking of conveying goods and error diagnostics 	<ul style="list-style-type: none"> • Function as input/output card • Transmits the status of all sensors, RollerDrive and, if necessary, error information to the PLC

CONTROLS

MULTICONTROL AI

For EC5000 24 V, 48 V
20 W, 35 W, 50 W with analog interface

Technical data

Electrical data	
Rated voltage	24 or 48 V DC
Voltage range	24 V DC: 22 to 28 V DC 48 V DC: 44 to 56 V DC (voltage supply of RollerDrive only)
Current consumption	Logic supply voltage: MultiControl: max. 0.2 A + connected sensors/actuators = max. 1.6 A + current of RollerDrive EC5000*
Fuses	– For logic – For RollerDrive – For sensors and I/Os, can be reset
Protection rate	IP54
Ambient conditions	
Ambient temperature in operation	–30 °C to +40 °C
Ambient temperature during transport and storage	–40 °C to +80 °C
Max. installation height above sea level	1000 m**

* The power of EC5000 depends on the application, e.g., conveying good weight, conveying speed, acceleration ramp, and on the EC5000 used (refer to the corresponding chapter).

** The installation in systems at an altitude above 1000 m is possible. However, this can lead to a reduction of the performance values.

APPLICATION NOTES

WHAT ARE APPLICATION NOTES USED FOR?

What are application notes used for?

The application notes support you during the planning and dimensioning of conveyor systems, as well as during the selection of Interroll conveyor modules.

The application notes offer the following:

- Basic rules for trouble-free transport
- Decision-making aids for product selection
- Calculation examples for the dimensioning of the conveyor modules and drive performances

In addition, your Interroll customer representative will be happy to assist you in the selection of conveyor modules, especially if you require specific measures due to special conveying goods or environmental conditions.

You should answer three questions before selecting a conveyor module:

Which tasks should the conveyor technology handle?

- Transporting and/or storing
- Sorting and/or distributing

What properties does your conveying good have?

- Length, width and height: Minimum and maximum dimensions of the transport materials which are conveyed together on one line
- Weight: Minimum and maximum weight of unit loads; ideally assigned to the dimensions
- Condition of the pallet underside: The bottom determines, e.g., the suitability of roller conveyors

Does the condition of your conveying good or the surroundings require special measures?

- For example, are there extreme temperatures, high humidity or chemical influences?
- Does electrostatic charging pose a problem?
- Is the conveying good fragile or problematic in any way?

Working with maximum values

Minimum and maximum performance data are listed at many points in this catalog. These extreme values, e.g., maximum permissible weight and maximum permissible speed, cannot always be combined with each other without restrictions. If you have any doubts, please contact your Interroll customer representative.

Weight classes

In general, Interroll groups conveyor technology by the weight of the conveying good into the following classes:

- Up to 35 kg: Light
- Up to 500 kg: Medium
- Up to 1500 kg: Heavy

This catalog includes conveyor modules up to 1200 kg, i.e., up to part of the Heavy weight class.

APPLICATION NOTES

CONVEYING GOOD

Conveying good

- The permissible dimensions, weight and conveying speed of the conveying good may not be exceeded, see "Technical data".
- The load capacity of the pallet must be sufficient for the weight of the conveying good.
- The weight must be evenly distributed on the pallet.
- For roller conveyors, more than three conveyor rollers must be located under the conveying good at all times.
- Conveying good dimensions, load stability and how the load is secured determine the conveying speed.
- The conveying good overhang on the pallet may not exceed 50 mm on any side.
- Only the types of pallets specified for the module may be transported.
- The conveying good height CGH depends on the center of gravity of the load.
Height of center of gravity < 1/2 conveying good height

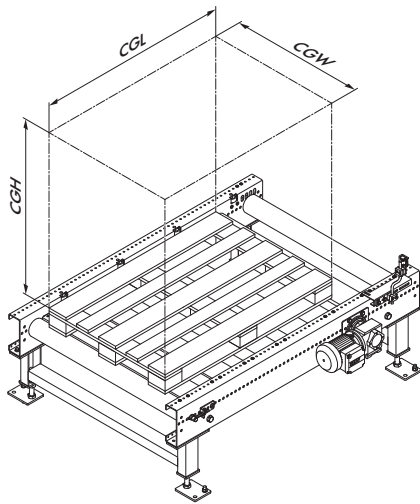

Size of conveying good = CGH x CGW x CGL

CGH	Conveying good height
CGW	Conveying good width
CGL	Conveying good length

Prerequisites for a safe transport:

- All outside long boards (1) are complete and undamaged.
- All cross boards are complete (2) and undamaged at the corners.
- The lower center board (3) is present and undamaged. There are no breaks along the entire length.
- All corner beams (4) are complete and not broken crosswise.
- All lower boards (5) are complete and dry. No board is broken crosswise.
- All nails are properly hammered in and do not protrude more than 2 mm.
- The bottom runners are free of plastic film.

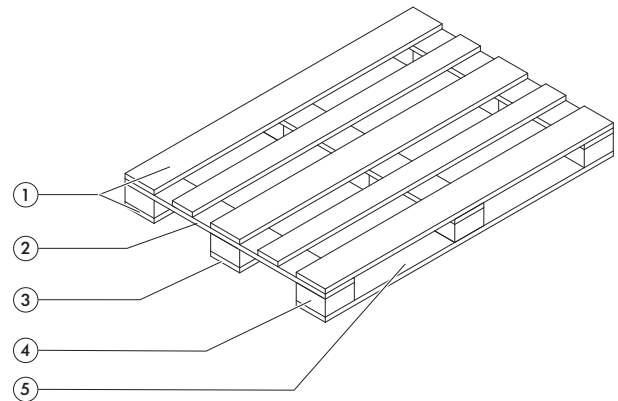

APPLICATION NOTES

BASIC PRINCIPLES FOR TROUBLE-FREE TRANSPORT

Basic principles for trouble-free transport

In order to transport the conveying good flawlessly on a roller conveyor, the following basic principles must be followed:

Roller pitch

The roller pitch must be selected so that at least five conveyor rollers are underneath the conveying good at any given time:

$$P \leq \frac{L}{5}$$

P	Roller pitch in mm (")
L	Conveying good length in mm (")

Load capacity

The weight of the conveying good must be distributed onto as many conveyor rollers as necessary so that the maximum load capacity of each individual conveyor roller is not exceeded. This may mean that more than five conveyor rollers must support the conveying good.

More information about conveyor rollers is available in Interroll's conveyor roller catalog.

Side profile

Steel profile 200 x 70 x 4 mm

- Standard profile for all roller conveyors
- Folded steel profile with powder coating
- The top edge of the roller is always 30 mm deeper than the top edge of the profile
- The side profile serves as side guide
- The profile has a continuous hole pattern in a grid of 25 mm for attaching all the required add-on components

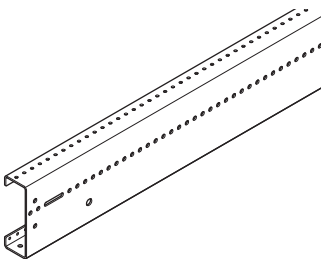

Fig.: Side profile

Profile connectors

The side profiles of the modules are connected form-fit with a profile connector. Each conveyor module includes 2 profile connectors.

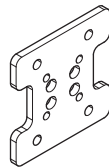

Fig.: Profile connectors

Supports

The supports are made of folded U-profiles 100 x 50 x 4 mm, which are assembled into a rigid frame. The supports can be attached in a grid of 25 mm at any location of the module (recommended support distance max. 1500 mm). In any event, a support must be attached at every track joint.

Throughput

The throughput T_p of a conveyor system is given in units/hour and depends on the size of the conveying good, the conveying speed and the cycle times of merging and diverting units.

The window size T is required for calculating the throughput. The window size T is the distance from the front edge of a conveying good to the front edge of the following conveying good, irrespective of the actual length of the conveying good or zone length.

For the precise calculation of the power capacity T_p , please contact your Interroll customer representative. T_p for straight paths can roughly be calculated as follows:

$$T_p = \frac{3,600 \cdot v}{T}$$

T_p	Throughput in units/hour
v	Conveying speed in m/s (ft/m)
T	Window size in m (")

With merging and diverting, throughput is additionally influenced by the actual length and weight of the conveying good as well as the transfer cycle. Please contact your Interroll customer consultant for calculations.

APPLICATION NOTES

TURNTABLES

Turntables

At the junctions of conveyor systems, pallets can be transferred via turntables from incoming conveyor lines onto tracks with different directions of travel.

Since they approach several positions in the swiveling range of 270° , they can be used as corner deflection, crossing or merger/diverter.

The direction of rotation must be specified by the controller of the conveyor systems.

Examples of applications

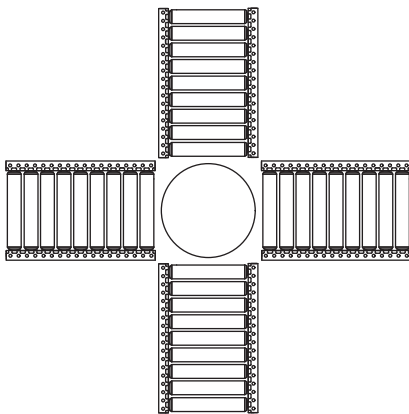

Fig.: Turntable crossing

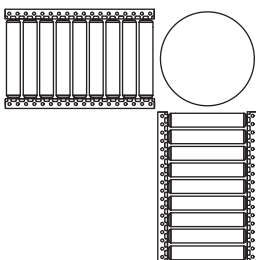

Fig.: Turntable 90° discharge

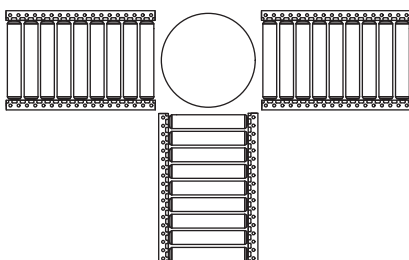

Fig.: Turntable diverter or merger

Transfer

The combination of roller and chain conveyors allows 90° transfers to implement complex intralogistical solutions in extremely tight spaces: They connect conveyor lines at a 90° angle and enable a change of direction of the load carriers.

For right-angle merging and diverting as well as for moving the conveying good between conveyor lines running in parallel, lifting elements are installed in the conveyor systems. The lifting motion is carried out electromechanically via eccentric lifting shafts.

Chain and roller transfers cannot be combined in a closed loop.

Examples of applications

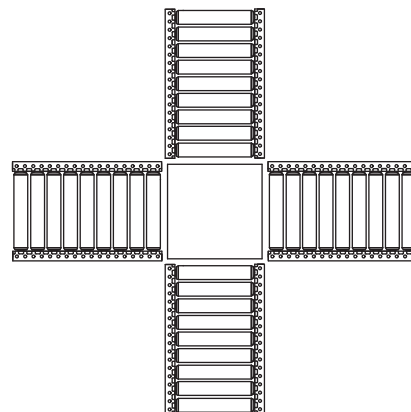

Fig.: Transfer crossing

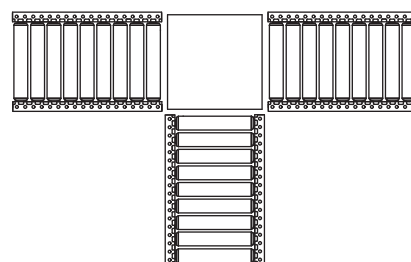
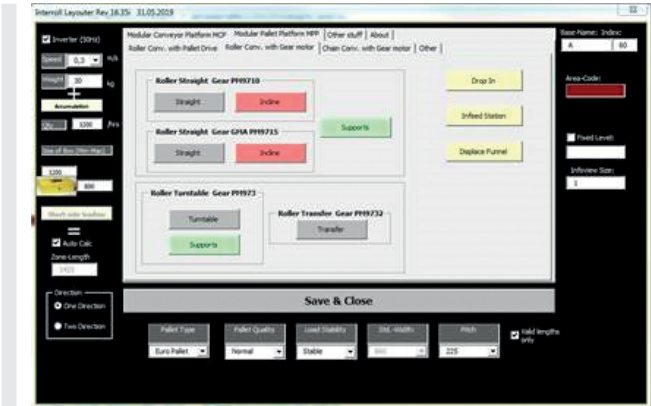

Fig.: Transfer diverter or merger

Interroll Layouter



The Interroll Layouter gives you a menu-driven tool that provides professional support in planning a conveyor system. Operating the software is very intuitive and makes it possible to compile an extensive 3D layout in DWG format from all Interroll conveyor modules.

All illustrated conveyor modules automatically feature a complete parameter set that makes it possible to simplify the electrical engineering process at the Integrator as well as the mechanical engineering process at Interroll. All parameters are exported to an Excel conveyor list which Interroll can use as the basis for creating price quotations, quickly and reliably.

System requirements:

- AutoCAD 2014 full version or later.
- Microsoft Office 2010 or later.

The Interroll Layouter is available as a plugin for AutoCAD where it can be launched and used via a separate menu.

For additional information and operational support, please contact your Interroll customer representative.

APPLICATION NOTES

INTERROLL LAYOUTER



LEGAL NOTICES

Contents

We strive for the information presented to be correct, up to date and complete. We have carefully developed the contents of this document. Nevertheless, errors and changes are expressly subject to change.

Copyright/intellectual property right

Text, images, graphics and the like, as well as their arrangement, are protected by copyright and other protective legislation. Reproduction, modification, transfer or publication of any part or the entire content of this document in any form is prohibited. This document is intended exclusively for informational purposes and for intended use and does not

authorize replication of the corresponding products. All identification symbols used in this document (protected trademarks, such as logos and commercial designations) are the property of Interroll AG or their respective owners and may not be used, copied or disseminated without prior written permission.

About Interroll

The Interroll Group is a globally leading provider of solutions for material handling. The company was founded in 1959 and has been listed on the SIX Swiss Exchange since 1997. Interroll supplies system integrators and machine builders with a broad product range of platform-based products and services in the categories "Rollers" (conveyor rollers), "Drives" (motors and drives for conveyor systems), "Conveyors & Sorters" as well as "Pallet & Carton Flow" (flow storage systems). Solutions from Interroll are used by express and postal services, in e-commerce, in airports and in the areas of food & beverage, fashion, automotive and other industries. The company counts leading brands, such as Amazon, Bosch, Coca-Cola, DHL, Nestlé, Procter & Gamble, Siemens, Walmart, or Zalando, among its users. Interroll, with its headquarters in Switzerland, features a global network of 34 companies with annual revenues of roughly 559.7 million francs and 2400 employees (2019).

[interroll.com](https://www.interroll.com)

INSPIRED BY
EFFICIENCY